



LONGS MOTOR

DM420A

PWM CURRENT CONTROL

Introduction:

DM420A is a type of two-phase hybrid stepping motor driver, The drive voltage of which is from 12VDC to 36VDC. It is designed for use with 2-phase hybrid stepper motor of all kinds with 20mm to 42mm outside diameter and less than 2.0A phase current. This circuit that it adopts is similar to the circuit of servo control which enables the motor run smoothly almost without noise and vibration. Holding torque when DM420A run under high speed is also significantly higher than the other two-phase driver, what's more, the positioning accuracy is also higher. It is widely used in middle and big size numerical control devices such as curving machine, CNC machine, and computer embroider machine, packing machines and so on.

Features:

- High performance, low price
- Average current control, 2-phase sinusoidal output current drive
- Supply voltage from 12VDC to 36VDC
- Opto-isolated signal I/O
- Overvoltage, under voltage, overcurrent, phase short circuit protection
- 8 channels subdivision and automatic idle-current reduction
- 8 channels output phase current setting
- Offline command input terminal
- Motor torque is related with speed, but not related with step/revolution
- High start speed
- High holding torque under high speed



Electrical specification:

Input voltage	12-36VDC
Input current	< 2A
Output current	0.44A- 2.83A
Consumption	Consumption : 40W ;
Temperature	Working Temperature -10 ~ 45°C ; Stocking temperature -40°C ~ 70°C
Humidity	Not condensation, no water droplets
gas	Prohibition of combustible gases and conductive dust
weight	70G

Pins assignments and description:

1) Connector Pins Configurations

Pin Function	Details
PUL +,PUL-	Pulse signal, PUL+ is the positive end of pulses input pin PUL- is the negative end of pulse input pin
DIR+,DIR-	DIR signal: DIR+ is the positive end of direction input pin DIR- is the negative end of direction input pin
ENBL+	Enable signal: ENBL+ is the positive end of direction input pin. This signal is used for enabling/disabling the driver. High level for enabling the driver and low level for disabling the driver.
ENBL-	ENBL- is the negative end of direction input pin. Usually left unconnected (enabled)

2) Pins wiring diagram:

PC's control signals can be active in high and low electrical level. When the high electrical level is active, all control negative signals will be connected together to GND. When low electrical level is active, all control positive signals will be connected together to public port. Now give two examples(Open collector & PNP), please check them:

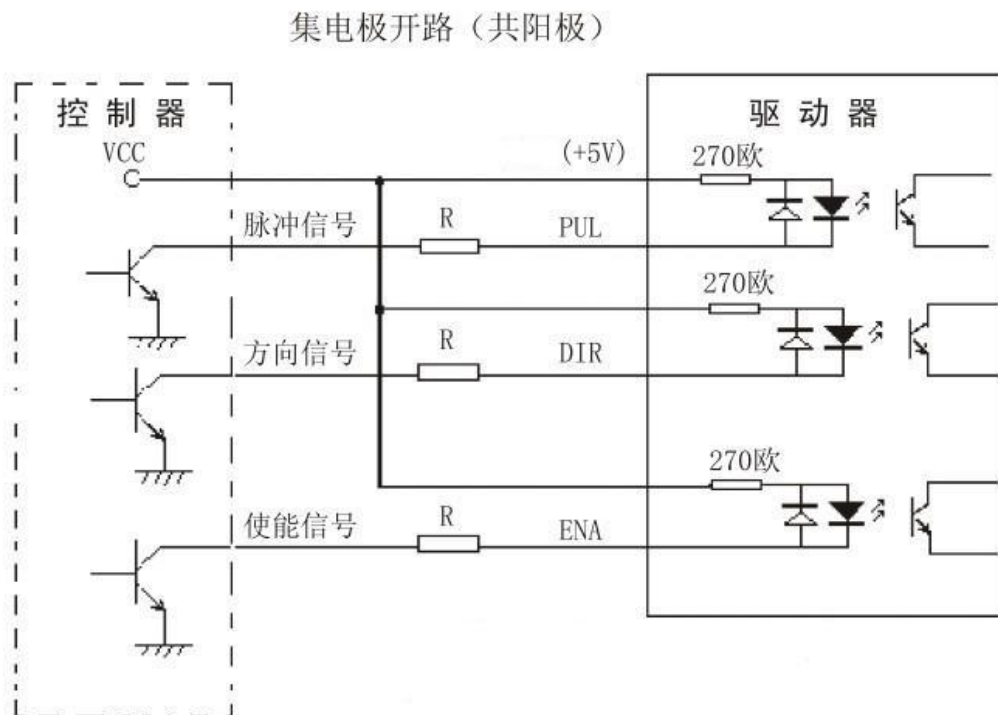

Fig 1. Input port circuit (Positive connection)

PC open connector output

PNP输出

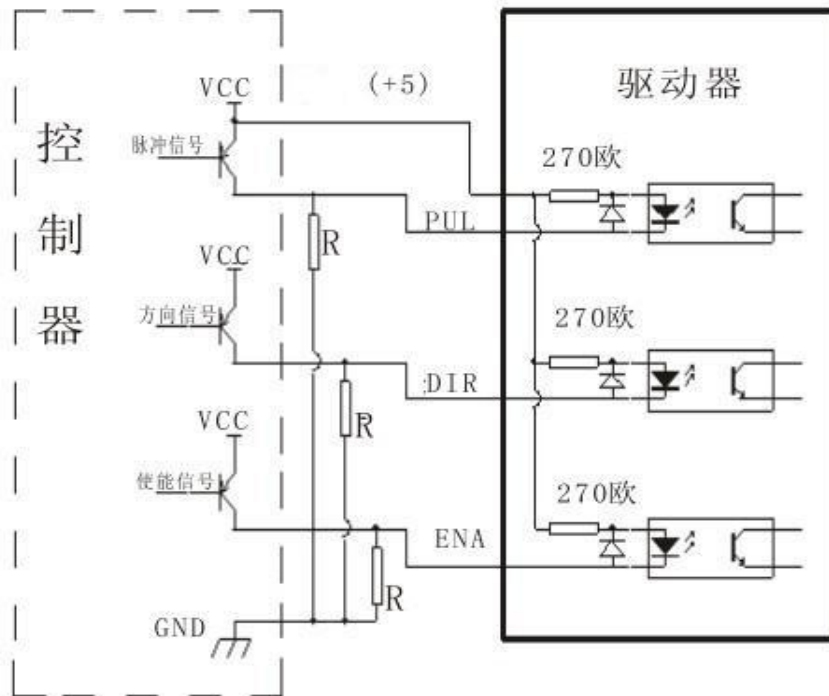

Fig. 2 Input port circuit (Negative connection)

PC PNP output

Note: When VCC=5V, R=0

When VCC=12V, R=1K, > 1/8W

When VCC=24V, R=2K, > 1/8W

R must connect in the control signal part .

3.Function choice (Using DIP pins to achieve this function)

1) Micro step resolution is set by SW 5,6,7,8 of the DIP switch as shown in the following table:



SW5	ON	OFF	ON	OFF	ON	OFF	ON	OFF
SW6	ON	ON	OFF	OFF	ON	ON	OFF	OFF
SW7	ON	ON	ON	ON	OFF	OFF	OFF	OFF
Pulse/rev	200	400	800	1600	3200	6400	12800	25600
Micro	1	2	4	8	16	32	64	128

2) Standstill current setting

SW4 is used for this purpose. OFF meaning that the standstill current is set to be half of the selected dynamic current and ON meaning that standstill is set to be the same as the selected dynamic current.

3) Output current setting:

The first three bits (SW 1, 2, 3) of the DIP switch are used to set the dynamic current. Select a setting

Closest to your motor's required current

SW1	SW2	SW3	PEAK	RMS
ON	ON	ON	0.44 A	0.31 A
OFF	ON	ON	0.62 A	0.44 A
ON	OFF	ON	0.74 A	0.52 A
OFF	OFF	ON	0.86 A	0.61 A
ON	ON	OFF	1.46 A	1.03 A
OFF	ON	OFF	1.69 A	1.20 A
ON	OFF	OFF	2.14 A	1.51 A
OFF	OFF	OFF	2.83 A	2.00 A

4) Semi-flow function:

Semi-flow function is that there is not step pulse after 200 ms, the driver output current automatically reduced to 40% of rated output current, which is used to prevent motor heat.



4. Pins of motor & power:

Motor and power pins	1	A+	Motors wiring	
	2	A-		
	3	B+		
	4	B-		
	5,6	DC+ DC-	Power supply	Power supply : DC12-36VDC The peak input current cannot be up to 2A

5. Mechanical Specification:

To have 20mm of space around ,cannot be placed next to other heating devices. What's more, avoid dust, oil mist, corrosive gas, heavy humidity and high vibration. (Unit=mm)

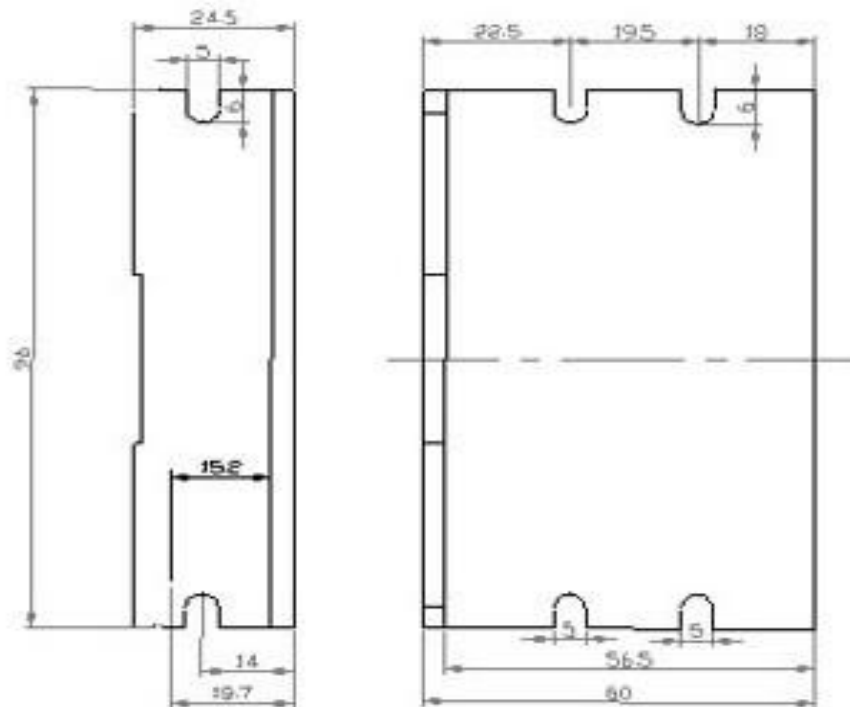

pic 3



6. Adjustment of troubleshooting

1) , the status on light's indication

PWR: green, normal work light.

ALM: red, failure light, the motor with phase short-circuit, overvoltage and under-voltage protection.

2) Troubles

Alarm indicator	Reasons	Measures
LED off turn	Wrong connection for power	Check wiring of power
	Low-voltages for power	Enlarge voltage of power
Motor doesn't run, without holding torque	Wrong connection of stepper motor	Correct its wiring
	RESET signal is effective when offline	Make RESET ineffective
Motor doesn't run, but maintains holding torque	Without input pulse signal	Adjust PWM & signal level
Motor runs wrong direction	Wrong wires' connection	Change connection for any of 2 wires
	Wrong input direction signal	Change direction setting
Motor's holding torque is too small	Too small relative to current setting	Correct rated current setting
	Acceleration is too fast	Reduce the acceleration
	Motor stalls	Rule out mechanical failure
	Driver does not match with the motor	Change a suitable driver

7. Driver wiring

A complete stepper motor control system should contain stepper drives, DC power supply and controller (pulse source). The following is a typical system wiring diagram

